



INSTRUCTION MANUAL

HF AUTOMATIC
ANTENNA TUNER

AT-140



FOREWORD

Thank you for purchasing the **AT-140 HF AUTOMATIC ANTENNA TUNER**.

The AT-140 is designed, primarily for use with Icom HF transceivers.

Refer to your HF transceiver instruction manual for operation. If you have any questions, contact your dealer.

IMPORTANT

READ ALL INSTRUCTIONS carefully and completely before using the AT-140.

SAVE THIS INSTRUCTION MANUAL. This instruction manual contains important safety and installation instructions.

EXPLICIT DEFINITIONS

Word	Definition
⚠ WARNING	Personal injury, fire hazard or electric shock may occur.
CAUTION	Equipment damage may occur.
NOTE	If disregarded, inconvenience only. No personal injury, fire hazard or electric shock.

SUPPLIED ACCESSORIES

The following accessories are supplied with the AT-140.

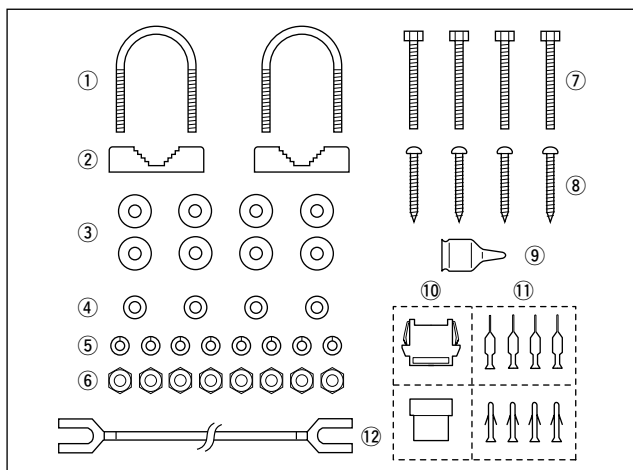

PRECAUTIONS

⚠ DANGER HIGH VOLTAGE! NEVER touch the antenna terminal, ground terminal, antenna or counterpoise while transmitting. Place the AT-140, antenna and counterpoise in positions where no one can touch them.

NEVER use without a ground connection.

NEVER transmit during internal adjustment. This may cause an electric shock.

USE the ground terminal for ground connection. The mounting plate is not connected internally.

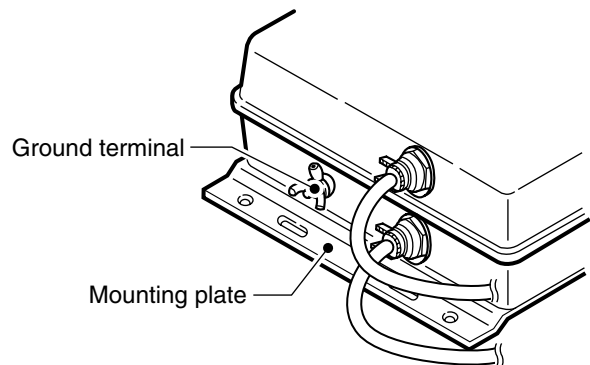

DO NOT operate your HF marine transceiver without running the boat's engine.

AVOID using the AT-140 in areas where the temperature is below -30°C (-22°F) or above $+60^{\circ}\text{C}$ ($+140^{\circ}\text{F}$).

Qty.

① U-bolts	2
② U-bolt plates	2
③ Flat washers (M6 large)	8
④ Flat washers (M6 small)	4
⑤ Spring washers (M6)	8
⑥ Nuts (M6)	8
⑦ Hex head bolts (M6×50)	4
⑧ Self-tapping screws (A0 6×30)	4
⑨ Weatherproof cap	1
⑩ 4-pin/6-pin connector*	1
⑪ Connector pins*	4
⑫ Ground cable (OPC-412)	1

*The supplied connector and pins are differ according to version.

Icom, Icom Inc. and the COM are registered trademarks of Icom Incorporated (Japan) in the United States, the United Kingdom, Germany, France, Spain, Russia and/or other countries.

MISCELLANEOUS ITEMS

The following parts are additionally required for installation, but are not supplied with the AT-140. Purchase these parts locally.

- ① AWG 14×4-conductor shielded cable
*Icom offers an optional OPC-1147/N control cable.
Length: 10 m; 32.8 feet
- ② 50 Ω coaxial cable
- ③ PL-259 connectors

FEATURES

Matches all bands

The AT-140 matches any frequency on every HF marine band. For example, the tuner matches a 7 m; 23 ft long-wire antenna across 1.6–30 MHz.

Full automatic tuning

Just push the [TUNE] switch on the transceiver, and the AT-140 adjusts immediately to the minimum SWR of any frequency on any HF marine band.

HF operation on any size ship

The AT-140 allows you HF operation where antenna element length is restricted due to space.

Weather resistant

The AT-140 is housed in a durable, completely weather resistant ASA case with a rubber gasket. The antenna tuner can be conveniently installed both on the deck or in the cabin near the antenna element.

Simple installation

Installation is simple. Just connect the control and antenna cables. You never need to open the cover.

45 memories for shorter tuning time

To decrease the tune-up time, the AT-140 automatically stores the matching conditions for up to 45 frequencies. Re-tuning for a memorized frequency takes approx. 1 sec.

Super capacitor for memory backup

Even if the AT-140 is not used for approx. 1 week, the built-in super capacitor backs up contents of the 45 memories.

Low power tune up

The AT-140 emits low output power during tuning. This feature reduces the possibility of causing interference to other stations.

Tuner through function

The tuner through function is built into the AT-140. This function helps improve receiver gain, depending on the antenna element length used, and operating frequency.

TABLE OF CONTENTS

FOREWORD.....	i
IMPORTANT	i
EXPLICIT DEFINITIONS	i
PRECAUTIONS	i
SUPPLIED ACCESSORIES	i
MISCELLANEOUS ITEMS.....	ii
FEATURES	ii
TABLE OF CONTENTS	ii
1 ANTENNA SYSTEM	1–2
■ Antenna for ship	1
■ Antenna for land operation	1
■ Coaxial cable.....	2
■ Ground and counterpoise	2
2 INSTALLATIONS	3–5
■ Installation outline.....	3
■ Control cable	3
■ PL-259 connector.....	4
■ Mounting	4
■ Cable connections	5
3 CONTROL CABLE SIGNALS	6–7
■ Terminal information	6
■ Transceiver setting	7
4 UNIT DESCRIPTION AND SPECIFICATIONS ...	8
■ Unit description.....	8
■ Specifications	8

■ Antenna for ship

Required antenna element length

Required antenna element length to achieve full performance varies according to the lowest frequency:

The lowest frequency	Required antenna element length
1.6 MHz band	7 m; 23.0 feet or longer
4 MHz band	3 m; 9.8 feet or longer

The longer the antenna element, the better the antenna efficiency.

Undesirable antenna element lengths

AVOID multiples of $\frac{1}{2}\lambda$ (half wavelength) for antenna element lengths, since tuning becomes difficult.

L : Antenna element length to be avoided [m]

f : Operating frequency [MHz]

n : Natural number (n = 1, 2, 3, ...)

$$L = \frac{300}{f} \times \frac{1}{2} \times n$$

[Example]

At an operating frequency of 16 MHz, avoid the following antenna element lengths:

$$L = \frac{300}{16} \times \frac{1}{2} \times n \approx 9.4, 18.8, \dots$$

1 m \approx 39 inches

For example, if 15 m is selected for an antenna element length, you have no problem in the 1.6–25 MHz marine bands range.

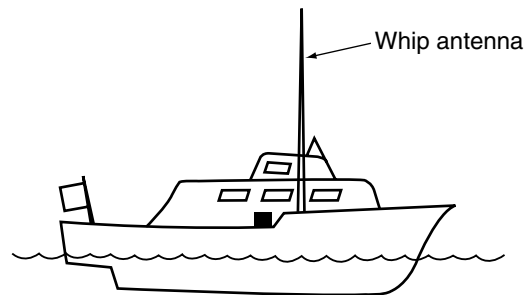
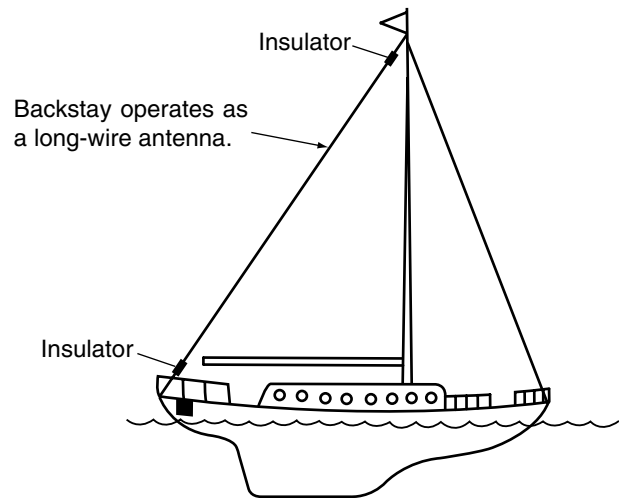

NOTE: Keep antennas as far away from other objects as possible, especially metal objects.

■ Antenna for land operation

In some countries, HF transceivers can be used for land mobile operation. Ask your Icom Dealer for details, since the radio law varies according to each country.

For land mobile operation on 4 MHz and above, an optional AH-2b ANTENNA ELEMENT is available. The AH-2b includes a sturdy tow hook mount system for holding a 2.5 m; 8.2 feet stainless steel antenna element plus all the necessary hardware.

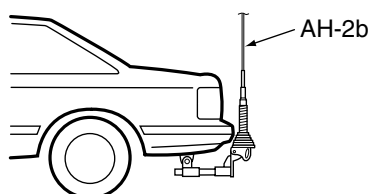

Refer to the AH-2b instruction manual for the AH-2b and AT-140 installation to your vehicle. Ask your Icom Dealer for details.

Connect a suitable antenna element for a base station. To achieve full performance, refer to "Required antenna element length" above.

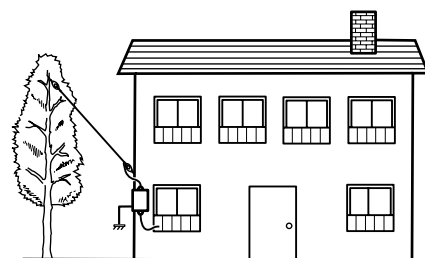

■ Coaxial cable

Insulate the lead-in cable of the AT-140 antenna terminal and antenna element from other metal objects.

To prevent interference, keep cables as far as possible from an antenna, electric pump and other electronic equipment.

To prevent erroneous indications, keep cables as far away as possible from the flux gate compass.

Use suitable noise filters for alternators, fluorescent lights, etc. Ask your Dealer for details.

■ Ground and counterpoise

Why a ship's ground is required

The AT-140's ground terminal **MUST** be connected to your ship's ground. Grounding prevents electric shocks, interference to other equipment and other problems. Grounding also ensures effective signal transmission.

DANGER! NEVER connect the ground terminal to the following points. These connections may cause an explosion or electric shocks:

- Gas or electrical pipe
- Fuel tank or oil-catch pan

IMPORTANT! The mounting plate is **NOT** connected to the AT-140's internal ground.

Ideal ground points

One of following points is ideal:

- External ground plate
- External copper screen
- External copper foil

Good ground points

If electrically connected to sea water, one of the following points is usable:

- Stainless steel stanchion
- Through mast
- Through hull
- Metal water tank

Undesirable ground points

AVOID the following points, if possible. These connections may cause noise or electrolysis:

- Engine block
- Ship's DC battery ground

Electrolysis

All ground cables from the AT-140, HF transceiver, etc. on your ship should be connected to only 1 ship's ground.

AVOID connection to 2 or more points. Voltage difference between 2 or more ship's grounds may cause electrolysis.

AVOID connection between dissimilar metals where an electric current is present. These connections may cause electrolysis.

Counterpoise

If your ship is made of FRP, etc. and a good ship's ground is not available, connect a counterpoise.

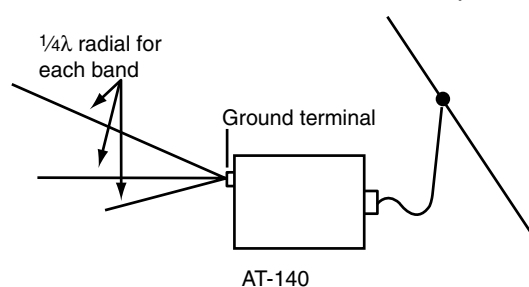

$\frac{1}{4}\lambda$ (quarter wavelength) radial for each band is suitable for a counterpoise. Install the counterpoise directly below the AT-140's ground terminal. Insulate the ends of each radial from other metal objects. Layout the radial horizontally and as straight as possible.

L : Counterpoise length for the operating frequency [m]
f : Operating frequency [MHz]

$$L = \frac{300}{f} \times \frac{1}{4}$$

[Example]

At an operating frequency of 16 MHz, use a counterpoise with the following length:

$$L = \frac{300}{16} \times \frac{1}{4} \approx 4.7 \text{ [m]}$$

1 m \approx 39 inches

Ground cable

For best results, use the heaviest gauge wire or metal strap available. Make the distance between the AT-140's ground terminal and ship's ground as short as possible.

Supplied ground cable can be used for ground connection to a through mast. Confirm that the through mast is electrically connected to sea water.

⚠ WARNING!— When grounding to metal hull
Use a Zinc anode to protect the hull from electrolysis.

Ask your technical dealer, installer or refer to a technical book, etc., for RF ground details.

■ Installation outline

- ① Connect a control cable and 4-conductor shielded cable.
 - Refer to "Control cable" below.
- ② Connect and solder the PL-259 connector to the coaxial cable.
 - Refer to p. 4 "PL-259 connector."
- ③ Mount the AT-140 in the desired location.
 - Refer to p. 4 "Mounting."
- ④ Connect the control cable and the coaxial between the transceiver and the AT-140.
 - Refer to p. 5 "Cable connections."
- ⑤ Connect an antenna, ship's ground or counterpoise.
 - Refer to p. 1 "Antenna for ship" and p. 2 "Ground and counterpoise."

■ Control cable

Between the AT-140 and HF marine transceiver, connect 4 control signal lines as shown below. To prevent RF feedback, use a 4-conductor shielded cable. Connect the shield line to the [GND] terminal on the transceiver. Icom offers 10 m (32.8 ft) long optional control cables as at right.

OPC-566 : for IC-M710/RT, M700PRO
 OPC-1147/N : for IC-M802

Refer to p. 6 "Terminal information" for details.

◇ When connecting to Icom IC-M802

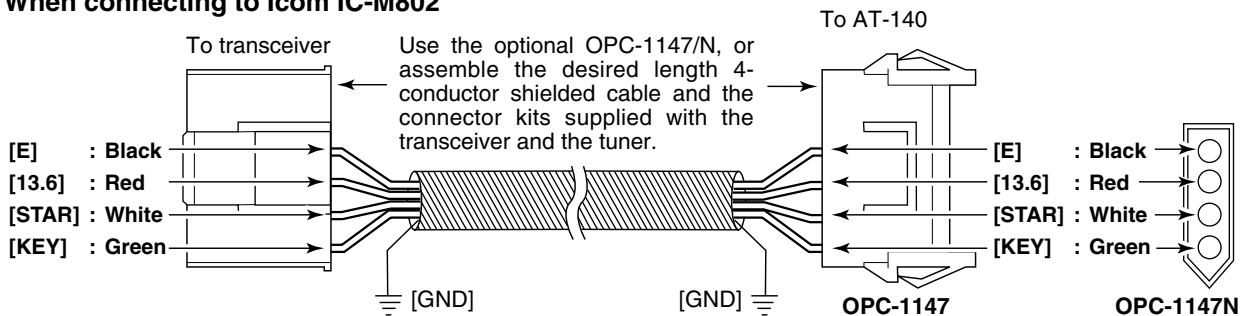

◇ When connecting to Icom IC-M710/RT, IC-M700PRO

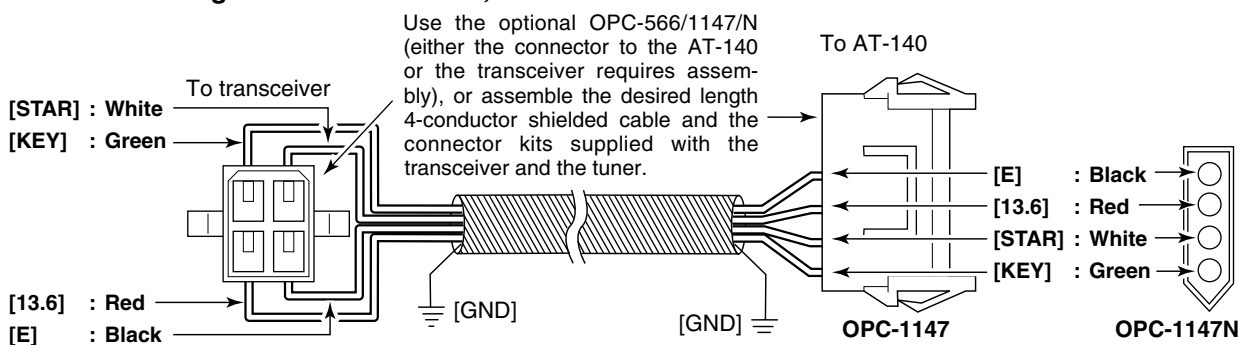

◇ When connecting to Icom IC-M700/TY, IC-78

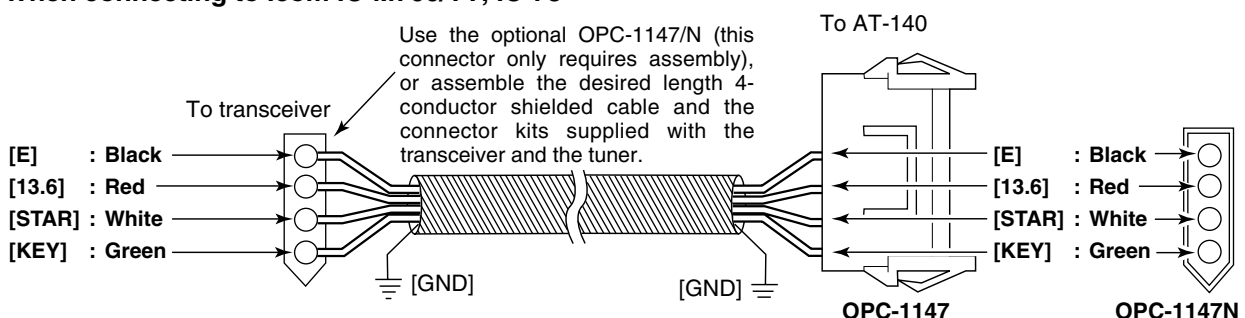

■ PL-259 connector

- ① Slide the coupling ring over the coaxial cable. Strip the cable jacket and pull back to reveal 10 mm of braid.

- Soft solder the exposed braid and then pull out the jacket.

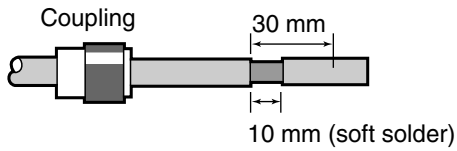

- ② Strip the cable as shown below. Soft solder the center conductor the entire length of the exposed braid.

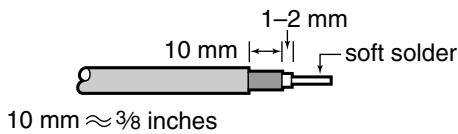

- ③ Slide the connector body over the cable and solder as shown below.

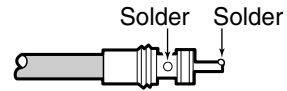

- ④ Screw the coupling ring onto the connector body.

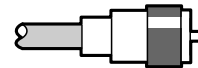

■ Mounting

Mounting on a Mast/Metal pole

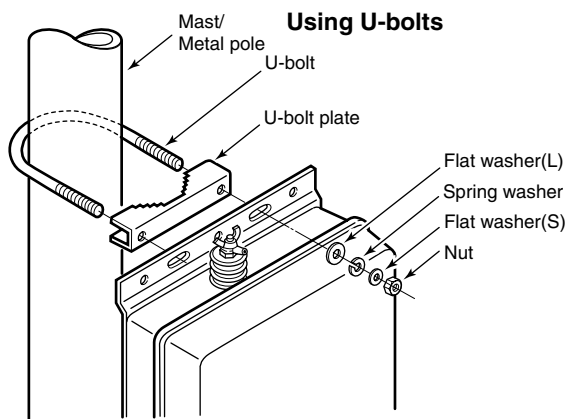

WARNING: Mount the AT-140 securely with the supplied nuts and bolts. Otherwise, vibrations and shocks due to waves, etc. could loosen the antenna tuner making it fall, causing personal injury.

Mounting on a flat surface

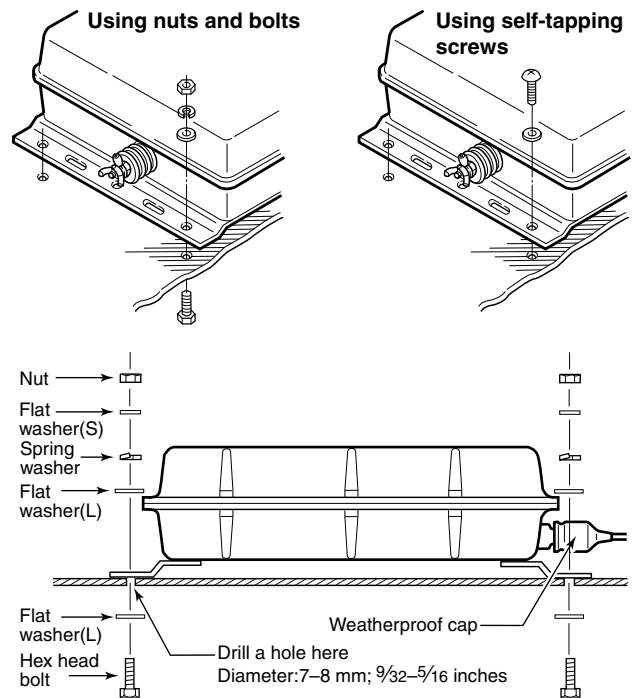

■ Cable connections

- ① Connect the coaxial cable and the control cable to the AT-140 as illustrated below.
- ② Cover both the antenna and the control cable connectors with rubber vulcanizing tape and fix it with a vinyl tape to prevent water seeping into the connector.

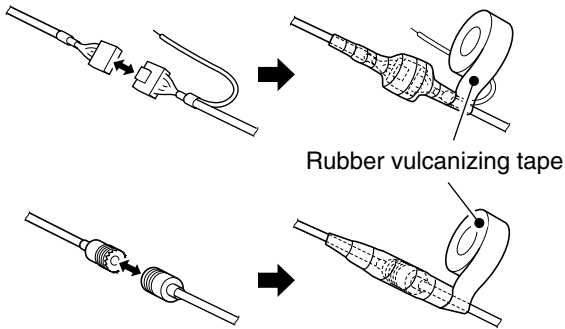

- ③ Fix both of the coaxial and control cables to protect the inside connections.

DO NOT pull the antenna and control cable receptacles. This may cause disconnection (in the AT-140), internal connector damaged or bad connection.

- ④ Connect the coaxial cable and the control cable to the transceiver as illustrated below.
- ⑤ Ground the transceiver, AT-140 and shield cable of the control cable via the ground terminal.
 - See pgs. 2 and 7–10 for grounding details.

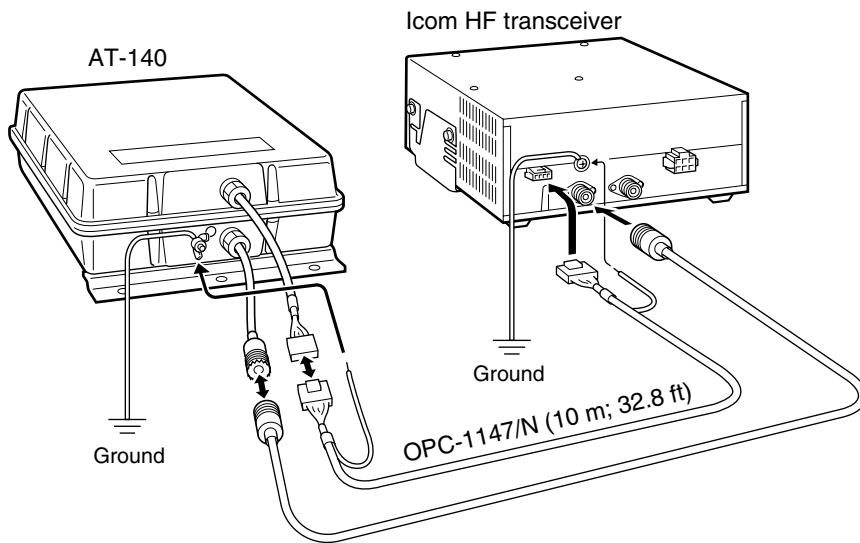
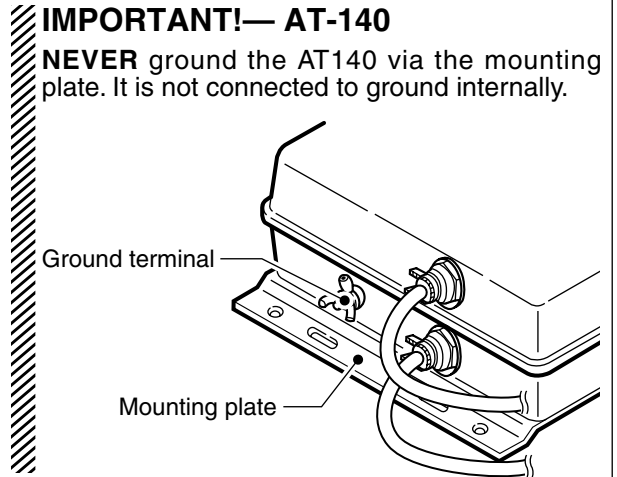

Terminal information

Consider the following points when using a non-Icom transceiver.

Terminal	Description
[KEY]	Key voltage. Grounded during tuning. Max. current drain 100 mA.
[13.6]	13.6 V DC ⊕ input terminal. Max. current drain 2 A
[STAR]	Receives start voltage. Max. current drain 1 mA
[E]	Ground terminal for above signals.

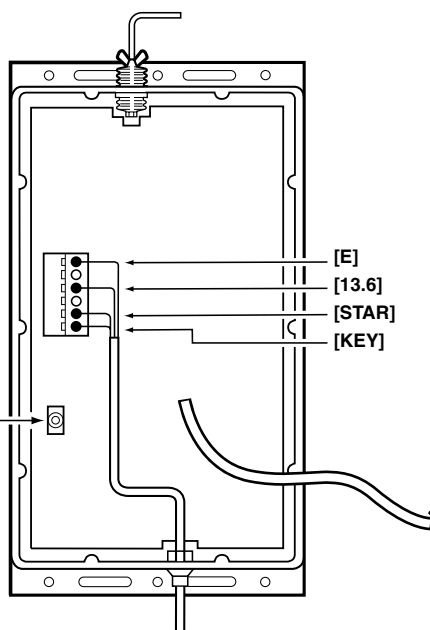
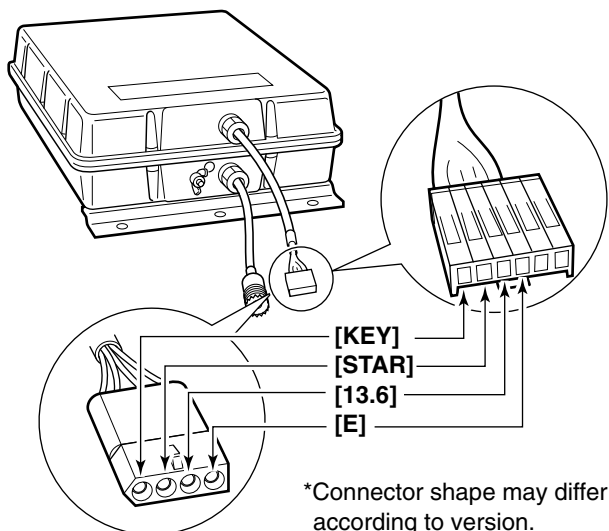

Start voltage [STAR]

When a start voltage (less than 1 V) is received, the AT-140 begins automatic tuning.

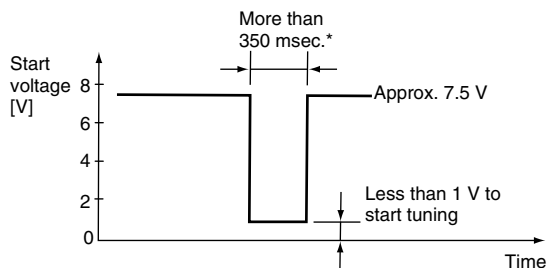

*For tuner through operation; Less than 250 msec.

Key voltage [KEY]

During automatic tuning, the AT-140 grounds the key voltage line, and the HF transceiver reduces output power.

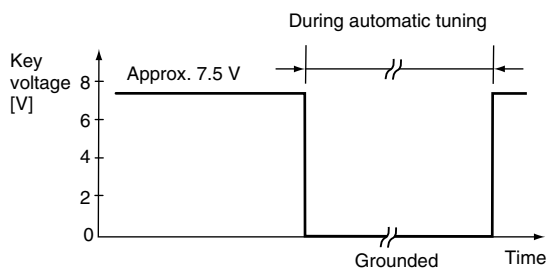

If the key voltage is more than 8 V, switch the mode switch (S1) to OFF mode (lower position).

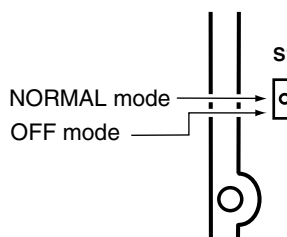

■ Transceiver setting

IC-M700 with serial number 2500 and below

In the IC-M700, change the [TUNE] switch setting from the “1” position to the “2” position. Confirm that the [KEY] switch is in the “2” position. Refer to the IC-M700 instruction manual p. 9 for details.

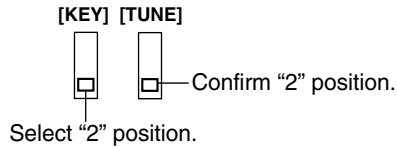

Other IC-M700 and IC-M700TY

Nothing necessary to set. However, the tuner through function is not available when using the AT-140 with IC-M700/TY.

IC-78

In the IC-78, select the antenna tuner type as “4* (AH-4)” in initial set mode. See IC-78 instruction manual p. 32 for details.

IC-M710/RT, IC-M700PRO

In the IC-M710/RT and IC-M700PRO, select the antenna tuner type as “AH-3*” in initial set mode. See IC-M710/RT instruction manual p. 13 or IC-M700PRO instruction manual p. 11 for details.

IC-M802

In the IC-M802, select the antenna tuner type as “AT-140” in initial set mode. See IC-M802 instruction manual p. 49 for details.

Non-Icom HF transceiver

Select correct settings for the start voltage and key voltage. Refer to your HF transceiver instruction manual for details.

NOTE: When a non-Icom automatic tuner was previously used, confirm the tuner settings. Refer to the instruction manual for details.

*With “AT-130” setting, use of the AT-140 is possible, however, the tuner through function cannot be operated.

■ Unit description

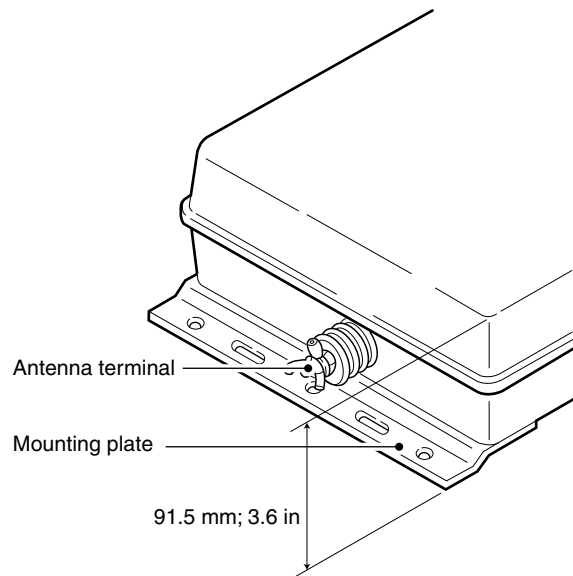
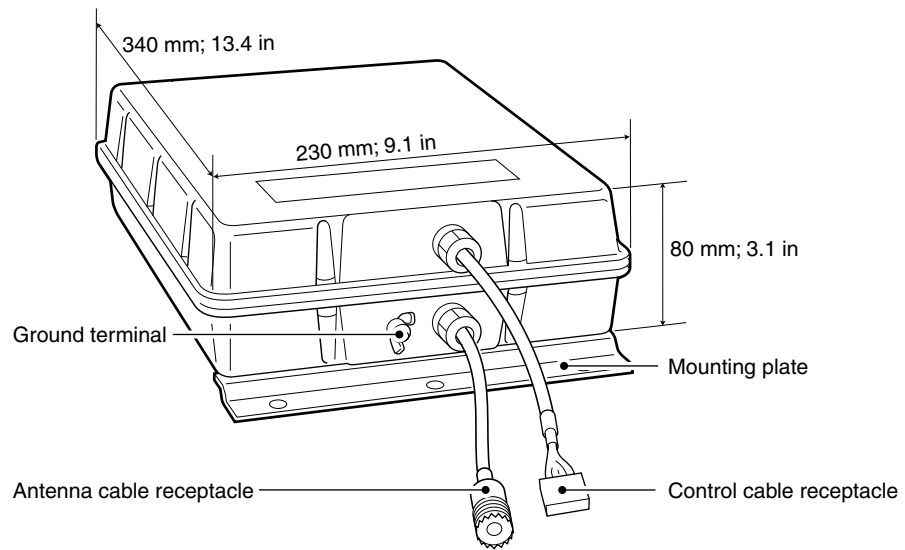

■ Specifications

- Frequency coverage : 1.6–30 MHz (with 7 m; 23.0 feet or longer antenna element)
- Power supply requirement : 13.6 V DC (supplied from HF transceiver)
- Current drain : Max. 2 A
- Operating temperature range : –30°C to +60°C (–22°F to +140°F)
- Weight : 2.5 kg; 5.5 lb
- Antenna connector : SO-239 (50 Ω)
- Max. Input power : 150 W (PEP) 100 W (continuous)
- Automatic tuning time : Approx. 2–3 sec. (general condition) Max. 15 sec.
Approx. 1 sec. (re-tuning for a memorized frequency)
- Automatic tuning accuracy : SWR 2.0:1 (after tuning, except for multiples of $\frac{1}{2}\lambda$)

All stated specifications are subject to change without notice or obligation.

Count on us!

Icom America Inc.

<Corporate Headquarters>
2380 116th Avenue NE, Bellevue, WA 98004, U.S.A.
Phone: +1 (425) 454-8155 Fax: +1 (425) 454-1509
URL: <http://www.icomamerica.com>
E-mail: sales@icomamerica.com
<Customer service>
Phone: (425) 454-7619

Icom (Europe) GmbH

Communication Equipment
Himmelgeister Str. 100,
D-40225 Dusseldorf, Germany
Phone: +49 (0211) 346047 Fax: +49 (0211) 333639
URL: <http://www.icomeurope.com>
E-mail: info@icomeurope.com

Icom Canada

Glenwood Centre #1150-6165 Highway 17, Delta,
B.C., V4K 5B8, Canada
Phone: +1 (604) 952-4266 Fax: +1 (604) 952-0090
URL: <http://www.icomcanada.com>
E-mail: info@icomcanada.com

Icom Spain S.L.

Ctra. Rubi, No. 88 "Edificio Can Castanyer"
08190, Sant Cugat del Valles, Barcelona, Spain
Phone: +34 (93) 590 26 70 Fax: +34 (93) 589 04 46
URL: <http://www.icomspain.com>
E-mail: icom@icomspain.com

Icom (Australia) Pty. Ltd.

Unit 1/103 Garden Road, Clayton Victoria, 3168,
Australia
Phone: +61 (03) 9549 7500
Fax: +61 (03) 9549-7505
URL: <http://www.icom.net.au>
E-mail: sales@icom.net.au

Icom (UK) Ltd.

Unit 9, Sea St., Herne Bay, Kent, CT6 8LD, U.K.
Phone: +44 (01227) 741741
Fax: +44 (01227) 741742
URL: <http://www.icomuk.co.uk>
E-mail: info@icomuk.co.uk

Icom New Zealand

146A Harris Road, East Tamaki, Auckland,
New Zealand
Phone: +64 (09) 274-4062 Fax: +64 (09) 274-4708
URL: <http://www.icom.co.nz>
E-mail: inquiries@icom.co.nz

Icom France s.a.s.

Zac de la Plaine,
1 Rue Brindejonc des Moulinais, BP 45804,
31505 Toulouse Cedex 5, France
Phone: +33 (5) 61 36 03 03
Fax: +33 (5) 61 36 03 00
URL: <http://www.icom-france.com>
E-mail: icom@icom-france.com

Asia Icom Inc.

6F No. 68, Sec. 1 Cheng-Teh Road, Taipei, Taiwan,
R.O.C.
Phone: +886 (02) 2559 1899
Fax: +886 (02) 2559 1874
URL: <http://www.asia-icom.com>
E-mail: sales@asia-icom.com

Icom Polska

Sopot, 3 maja 54, Poland
Phone: +48 (58) 550 7135 Fax: +48 (58) 551 0484
URL: <http://www.icompolska.com.pl>
E-mail: icompolska@icompolska.com.pl

A-6175H-1EX-③

Printed in Japan

© 2002–2008 Icom Inc.

Printed on recycled paper with soy ink.

Icom Inc.

1-1-32 Kamiminami, Hirano-ku, Osaka 547-0003, Japan
